

BRITISH RAILWAYS
WESTERN REGION

Newport Multiple Aspect
Signalling Scheme

INTRODUCTION OF STAGE I

At a date to be determined in the near future, Stage I of the Newport Multiple Aspect Signalling Scheme will be introduced.

For the information of all concerned, the attached is an advanced copy of the Notice which will be issued in due course.

It must be noted that this is not the Final Notice, and certain alterations may be necessary before the Final Notice is distributed.

C. H. D. READ,

District Traffic Superintendent.

NEWPORT.

February, 1961.
(W.1/10921.)

Received copy of Mr. C. H. D. Read's Advanced Notice No. W.886, re Introduction of Stage I of Newport Multiple Aspect Signalling Scheme.

.....DATESIGNATURE

.....DEPT.STATION

TO DISTRICT TRAFFIC SUPERINTENDENT,
NEWPORT (W1/10921)

BRITISH RAILWAYS

(WESTERN REGION)

Introduction of Stage 1 of Newport Multiple Aspect Signalling Scheme

Commencing at on and until
on or until completion, the Chief Signals
and Telecommunications Engineer and Chief Civil Engineer will be engaged carrying
out the following work in connection with the introduction of Stage I of the Newport
Multiple Aspect Signalling Scheme.

Various existing connections will be **taken out of use**, and new connections
brought into use.

A new fly-over bridge situated at 152m, 29ch. will be **brought into use**.

The revised lay-out and signalling will be as shown on the sketch enclosed.

The lines West of Magor will be redesignated as follows :—

Existing	Location	To Become
Down Goods ..	Magor to Fly-over Bridge	Down Relief
Down Main ..	Magor to Fly-over Bridge	Remains Down Main
Up Main ..	Fly-over Bridge to Magor	Remains Up Main
Up Goods ..	Fly-over Bridge to Magor	Up Relief
Down Goods ..	Fly-over Bridge to Maindee Jct. East	Down Relief
Down Main ..	Fly-over Bridge to Maindee Jct. East	Up Relief
Up Main ..	Maindee Jct. East to Fly-over Bridge	Down Main
Up Goods ..	Maindee Jct. East to Fly-over Bridge	Up Main
Down Loop ..	Maindee Jct. East to Newport East	Down Relief
Old Down Loop (at present out of use)	Maindee Jct. East to Newport East	Up Relief
Down Main ..	Maindee Jct. East to Newport East	Remains Down Main
Up Main ..	Newport East to Maindee Jct. East	Remains Up Main
Down Platform	Newport East to Newport West ..	Remains Down Platform
Down Main ..	Newport East to Newport West ..	Down Relief
Up Main ..	Newport West to Newport East ..	Up Relief
Up Platform ..	Newport West to Newport East ..	Up and Down Platform
Down Relief ..	Newport East to Newport West ..	Down Main
Up Relief ..	Newport West to Newport East ..	Up Main

(See later paragraph for extent of reversible working
and numbering of platforms)

Existing	Location	To Become
Down Main ..	Newport West to Gaer Jct.	Down Relief
Up Main ..	Gaer Jct. to Newport West	Up Relief
Down Relief ..	Newport West to Gaer Jct.	Down Main
Up Relief ..	Gaer Jct. to Newport West	Up Main

Throughout the remainder of this Notice, all lines will be referred to by their new names, unless otherwise stated.

SPEED OF TRAINS

The maximum permitted speeds of trains will be as under, subject to any temporary restrictions imposed from time to time :—

Down Main

Magor to 157m. 65ch. (Maindee Junction) ..	75 m.p.h.
157m. 65ch. to Newport East Signal Box ..	40 m.p.h.
Newport East Signal Box to Scissors in Platform ..	15 m.p.h.
Scissors in Platform to Newport West Signal Box	30 m.p.h.
Newport West Signal Box to Gaer Junction (159½ m.p.) ..	75 m.p.h.

Up Main

Gaer Junction (159½ m.p.) to Newport West Signal Box ..	75 m.p.h.
Newport West Signal Box to Scissors in Platform	30 m.p.h.
Scissors in Platform to Newport East Signal Box	15 m.p.h.
Newport East Signal Box to 157m. 65ch. ..	40 m.p.h.
157m. 65ch. to Magor ..	60 m.p.h.

Down and Up Relief Lines

Magor to Gaer Junction ..	40 m.p.h.
---------------------------	-----------

REVERSIBLE WORKING

1. Up Main

Between the new facing crossover on the Hereford Branch just clear of the junction with the main line at Newport East and the scissors crossover opposite Newport West Signal Box.

2. Down Main

Between the scissors crossover opposite Newport West Signal Box and the new crossover between the Main Lines on the Paddington side of the junction of the Hereford Branch with the Main Lines at Newport East.

3. Up and Down Platform

Throughout the whole length of this line.

PLATFORM NUMBERING

Platform numbering at Newport (High Street) Station will be altered as follows :—

Existing	To Become
Nos. 1 and 2 ..	No. 6 (Down Platform)
No. 3 ..	Bay
Nos. 4 and 5 ..	*No. 5 (Up and Down Platform)
Nos. 6 and 7 ..	*No. 2 (Down Main)
No. 8 ..	*No. 1 (Up Main)

* Reversible Working

EXISTING SIGNAL BOXES TO BE TAKEN OUT OF USE

The following existing Signal Boxes will be taken out of use, together with all semaphore signals and discs worked therefrom, except where stated :—

- Bishton.** But the box will be converted to a Ground Frame to control the level crossing (see later paragraph).
- Llanwern**
- Lliswerry Crossing**
- East Usk Junction.** With the exception of the signals on the East Usk Branch, which will be transferred to a new mechanical box, some of which will be changed in form and designation (see later schedule).
- Maindee Junction East.** With the exception of the existing Up Main Distant signals and the Up Maindee Loop Distant and Inner Distant which will be changed in name (see later paragraph).

SIGNALS TO BE TAKEN OUT OF USE

Signals worked from other boxes will be taken out of use as follows :—

1. Magor

Down Main Home
Down Main Inner Home
Down Main Starting to Down Goods
Down Main Starting
Down Main Advanced Starting
Disc—Down Main Inner Home to Up Goods
Up Main Distant
Up Main Home
Up Goods Home to Up Main
Up Goods Home
Disc—Up Goods Home to Up Siding

The Down Main colour light distant signal will be altered in form and will be capable of displaying yellow, double yellow, or green aspects.

2. Maindee Junction North

Up Distant	}	From Newport East
Up Intermediate Distant		
Up Inner Distant		
Distant	}	From Maindee Junction East
.. .. .		

3. Newport East

All signals and discs east of the 158¼ mile post, on both the Paddington and Hereford Lines, will be taken out of use, also the following signals :—

Down Relief to Down Platform Line Inner Home
Down Relief to Down Platform Line Calling on
Down Relief to Down Main Inner Home
Down Relief to Down Main Calling on
Down Relief Inner Home
Up Main Banner Repeater
Up Platform Banner Repeater
Up Main Home
Up Main to Up Relief Home
Up Platform to Up Main Home
Up Platform to Up Relief Home

No. 6 Platform Home
 No. 8 Platform Home
 Up Relief Starting
 Disc—Backing Down Up Relief or Up Relief to Down Platform
 Line, or Up Relief to Down Main or Up Relief to Backing
 Down Up Main.

Several other signals will be altered in name or form as described later. The Distant on the Down Hereford Line will remain.

Three shot detonators. The three shot detonators situated on the existing Up Main, Up Platform Line and No. 6 Platform Line will be recovered.

4. Newport West

Signals to be taken out of use :—

Down Main Distant	
Down Platform Line Distant	
Down Relief Distant	
Down Relief Intermediate Distant	
No. 3 Platform Line to Down Main Starting	
No. 3 Platform Line to No. 1 Goods Siding Starting	
Down Platform Line Home	} Bracket
Down Main Home	
Down Main to Down Relief Home	
Disc backing Down Up Main	
Disc backing Down Up Platform	
Disc backing from Up Platform Line to Up Platform Siding or Down Up Platform Line.	

Three Shot detonators. The three shot detonators situated on the existing Down Platform Line and Down Main will be recovered.

5. Gaer Junction

Signals to be taken out of use:—

Down Main (from Down Platform) Distant
 Down Main (from Down Main) Distant

TAKING OUT OF USE SPENCER WORKS GROUND FRAME

The Spencer Works Ground Frame will be taken out of use.

BRINGING INTO USE NEW MECHANICAL SIGNAL BOX AT EAST USK

A new mechanical signal box will be brought into use at East Usk situated on the Down Side of the line between East Usk Branch Line and Shunting Spur.

This Box will operate the connections leading to and from the Reception Lines, also the signals on the East Usk Branch.

BRINGING INTO USE NEW GROUND FRAME AT BISHTON CROSSING

The existing Bishton Signal Box will be converted to a Ground Frame to be known as Bishton Crossing Ground Frame. This will be released by interlocking lever controlled from a switch on the signalling control panel at Magor Signal Box.

At the Ground Frame a telephone will be provided to give exclusive communication to the controlling signal box.

INTRODUCTION OF MULTIPLE ASPECT SIGNALLING

Multiple Aspect Signalling will be brought into use between Magor and Newport East Signal Boxes to be operated from a new panel in the existing Magor Signal Box and temporary panels at East Usk (Relay House at 157m. 4ch.) and Maindee Main (Relay House at 157m. 26ch.).

The area covered by each control panel is indicated on the sketch attached.

Detailed instructions for the operation of the new control panels are contained in separate publications entitled "Description and Method of Operation of the Signalling Control Panel."

Method of Signalling

The Multiple Aspect Signals will generally be capable of displaying any one of four aspects in accordance with Rule 43, namely :—

Green	Clear, next signal exhibiting a proceed indication.
Two Yellows .. (Vertically displayed)	Preliminary caution. Prepare to pass next signal at restricted speed and to find it showing one yellow light, or two yellow lights in certain exceptional cases in closely signalled areas.
Yellow	Caution, be prepared to stop at the next signal
Red	Danger

A general description of this method of signalling, together with a description of other aspects and indications that will be encountered will be found on pages 19-22 of the Regional Appendix.

Symbols for Identification of Lines, Boxes and Signals

1. Lines. For the purpose of identification of the lines, each line will be allocated a single letter or number as follows :—

Up Main	1
Down Main	2
Up Relief	3
Down Relief	4
Up and Down Platform Line at Newport Station ..	5
Down Platform Line at Newport Station ..	6
East Usk Reception Siding No. 1	N1
East Usk Reception Siding No. 2	N2

The above designations will be displayed on Route Indicators, as detailed later.

2. Signal Boxes. The following prefix letters will be exhibited on the Signal Box :—

Magor	MG
East Usk (Panel)	U
East Usk (Mechanical)	MU
Maindee Main	M

3. Signals. All new signals will carry an identification plate as under :—

(a) Main and Relief Line Multiple Aspect Controlled Signals

These carry a plate bearing one or two letters, followed by a number.

The letters will be :—

MG ..	For those signals controlled from Magor Signal Box.
N ..	For all other signals.

In the case of signals prefixed by the letter N, the plate will carry three numerals, the first of these corresponding to the number of the line which the signal controls and the whole three figured number is odd for an Up direction signal and even for a Down direction signal.

(b) Other Multiple Aspect Signals and Position

Light Ground Shunt Signals

These carry a plate bearing one or two letters followed by a number.

The letters will be :—

U	..	For those signals controlled from East Usk (panel)
MU	..	For those signals controlled from East Usk (mechanical)
M	..	For those signals controlled from Maindee Main panel
W	..	For those signals controlled from Newport West Signal Box

The existing position light ground shunt signals at Newport West will not be numbered at this stage.

The number will be odd for Up direction signals and even for Down direction signals. The new position light ground shunt signals will also bear an arrow pointing towards the line to which the signal refers.

(c) Automatic Signals

These carry a plate bearing two letters followed by a three figured number. The two letters refer to the line which the signal controls and the number refers to the lower of the two mile posts between which the signal stands.

When two or more signals are located between mile posts they will be distinguished by an additional letter following the number, e.g. :—

UM : 154A	} All these signals are located between Mile Posts 154 and 155.
UM : 154B	
UR : 154A	
UR : 154B	
DM : 154	
DR : 154	

Block Telegraph Arrangements

The Block Sections will be re-arranged as follows :—

Existing		To Become
Magor	Bishton	} Magor to East Usk (TRACK CIRCUIT BLOCK)
Bishton	Llanwern	
Llanwern	Lliswerry Crossing	
Lliswerry Crossing	East Usk Junction	
East Usk Junction	Corporation Road ..	Permissive Block to remain
East Usk Junction	Maindee Junction East	East Usk to Maindee Main (TRACK CIRCUIT BLOCK)
Maindee Junction East	Newport East	Maindee Main to Newport East (TRACK CIRCUIT BLOCK)
Maindee Junction East	Maindee Junction North	Maindee Main to Maindee Junction North (TRACK CIRCUIT BLOCK)
Newport East	Maindee Junction North	Maindee Main to Maindee Junction North (TRACK CIRCUIT BLOCK) (Permissive Block on Up Hereford Goods)

Where Track Circuit Block is in operation Block Bells will be provided.

Until further notice these bells will be used for the purpose of train description and in an emergency.

Point Machines

All connections in and leading to and from the Main and Relief Lines between Bishton fly-over and the junction of the Hereford Branch with the Main Lines at Newport East inclusive will be worked by power from one of the three new signal control panels as indicated on the attached sketch.

All new point machines will be of the Westinghouse Brake and Signal Company's Style M3, and the relevant instructions for emergency operation are given in pages 139 and 140 of the Regional Appendix to the Rule Book.

The existing power operated points in the East Usk Branch will remain power operated from the new East Usk Mechanical Box, but the new type of point machine will be fitted.

Hand cranks and Keys for emergency operation of the point machines will be located as under :—

- (1) Bishton Crossing Ground Frame
- (2) East Usk (Mechanical)
- (3) East Usk (Panel)
- (4) Maindee Main
- (5) Newport East
- (6) Newport West

Power Operated Points

Points controlled from any of the three signalling Control Panels will have identification numbers fixed to the sleeper between the point tongues. This will be a three figured number followed by an arrow indicating the normal lie of the points.

Track Circuits

Existing track circuits will be re-arranged and new track circuits will be brought into use giving continuous track circuiting on all running lines between the West end of Magor Platforms and Gaer Junction.

A.W.S. Ramps

An A.W.S. Ramp will be provided for each Multiple Aspect Signal, except where otherwise stated in the schedule and it will normally be 200 yards to the rear of the signal except in the station area where this distance is varied due to point connections. These ramps will not necessarily be brought into use at the same time as the signal to which they apply, but will be brought into use as soon as possible afterwards.

New Signals

New signals will be brought into use according to the following schedule and will be located on the left of the line to which they apply unless otherwise stated.

The profiles referred to in the schedule are as follows :—

SIGNAL PROFILES

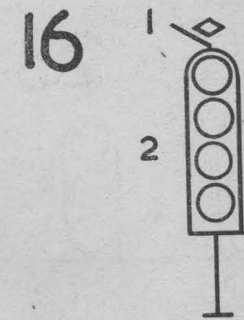
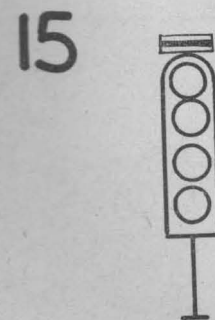
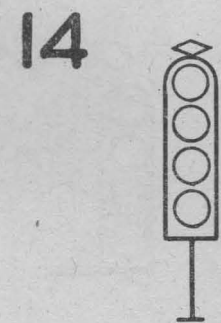
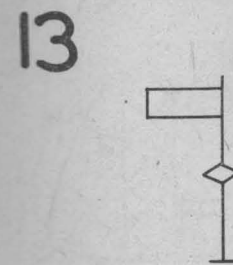
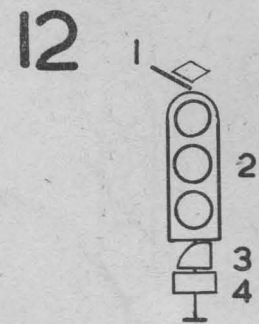
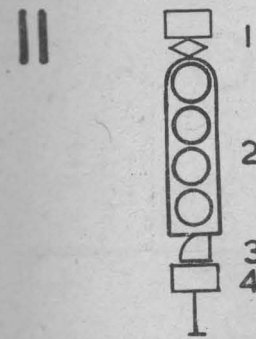
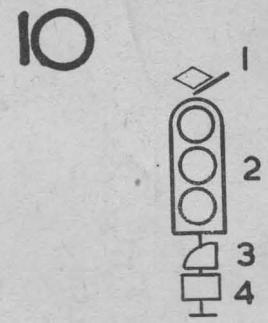
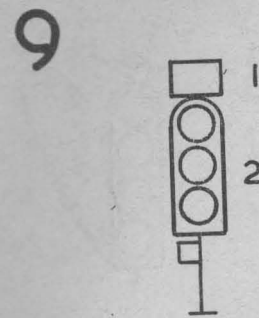
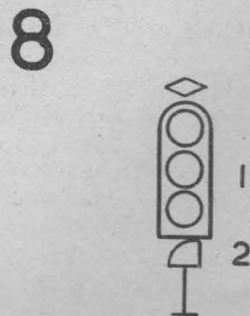
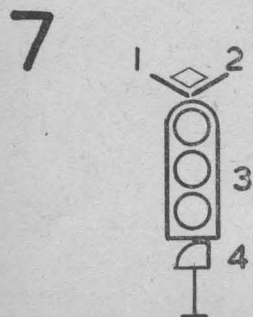
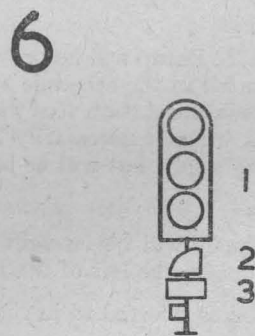
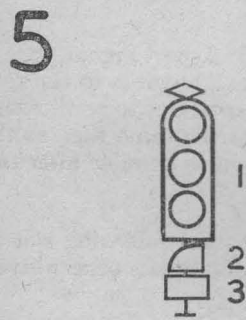
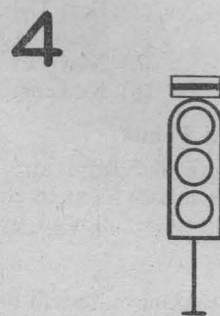
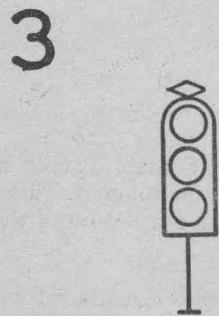
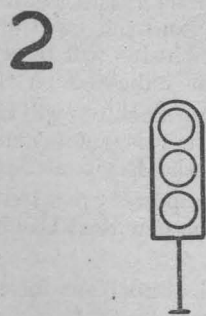
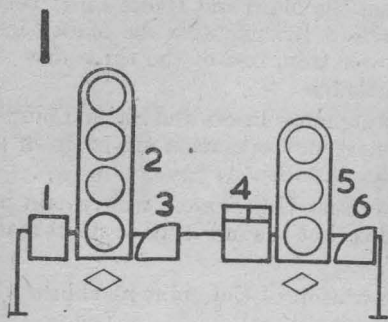

17

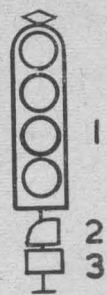

18

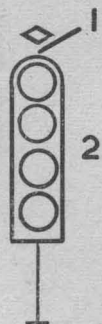

19

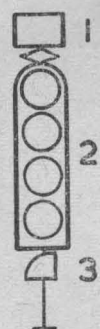

20

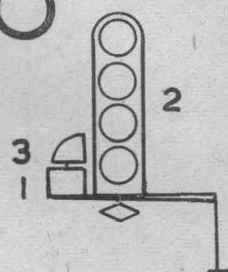

21

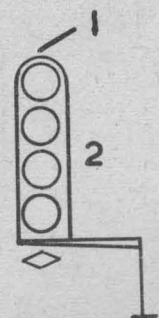

22

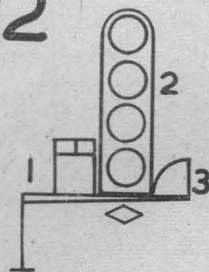

23

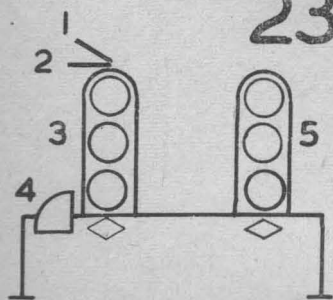

24



25

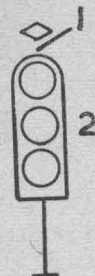

26

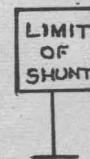

27

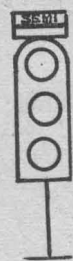

28

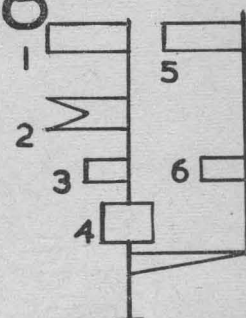

29

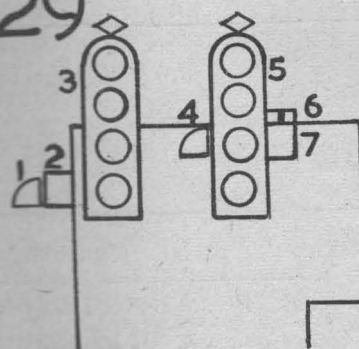

30

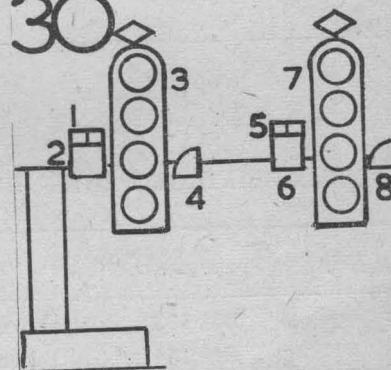

31



32

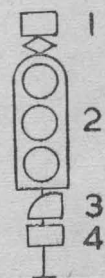

MAGOR (DOWN MAIN LINE)

PROFILE No.	SIGNAL No.	APPLICATION	MILEAGE
2	MG 47	Down Main Distant .. (can display green, double yellow or single yellow aspects)	150m. 132yds.
14	MG 46	Down Main Home ..	150m. 1,400yds.
12	MG 44	Down Main Inner Home .. 1. Junction Indicator to Down Relief working with Main aspect 2 (a) 2. Down Main to :— (a) Down Relief (Junction indicator displayed) (b) Down Main 3. Shunt. Down Main to Limit of shunt backing down the Up Relief (Route Indication "UR") 4. Route Indicator working with shunt aspect 3	151m. 100yds.
4	DM 151	Down Main	151m. 1,023yds.
4	DM 152A	Down Main	152m. 506yds.
4	DM 152B	Down Main	152m. 1,752yds.

EAST USK CONTROL PANEL (DOWN MAIN LINE)

PROFILE No.	SIGNAL No.	APPLICATION	MILEAGE
4	DM 153	Down Main	153m. 1,274yds.
4	DM 154	Down Main	154m. 823yds.
15	DM 155A	Down Main	155m. 326yds.
15	DM 155B	Down Main	155m. 1,634yds.
14	N 212	Down Main	156m. 572yds.
16	N 214	1. Junction Indicator to Down Relief working with Main Aspect 2 (a) 2. Down Main to :— (a) Down Relief (Junction Indicator displayed) (b) Down Main	156m. 1,253yds.

MAINDEE MAIN CONTROL PANEL (DOWN MAIN LINE)

PROFILE No.	SIGNAL No.	APPLICATION	MILEAGE
14	N 218	Down Main	157m. 790yds.
18	N 220	1. Junction Indicator to Down Maindee Loop working with Main Aspect 2 (b) 2. Down Main to :— (a) Down Main (b) Down Maindee Loop (Junction Indicator displayed) When showing a proceed aspect with Junction Indicator will act as Down Distant for Maindee Junction North When the signal is displaying a double yellow or a green without the Junction Indicator this signal acts as Down Main Distant for Newport East The A.W.S. Ramp, when approaching this signal over the crossover from the Down Relief will be 110 yards to the rear of the Signal	157m. 1,515yds.

(continued)

MAINDEE MAIN CONTROL PANEL (DOWN MAIN LINE) — continued

PROFILE No.	SIGNAL No.	APPLICATION	MILEAGE
16	N 222	<p>1. Junction Indicator to Down Relief working with Main Aspect 2 (a)</p> <p>2. Down Main to :—</p> <p>(a) Down Relief (Junction Indicator displayed)</p> <p>(b) Down Main</p> <p>This signal also acts as the Down Main and Down Main to Relief Inner Distant signals for Newport East, and also the Down Main, Down Relief and Down Platform Line Distant signals for Newport West</p> <p>The Indications are as follows :—</p> <p>Single Yellow : Caution for Newport East</p> <p>Double Yellow : Stop signals at Newport East off Caution for Newport West</p> <p>Green : Stop signals at Newport East and West off.</p>	158m. 150yds.
25	N 622 (Down Hereford Branch)	<p>1. Junction Indicator to No. 1 Line (Up Main), working with main aspect 2 (b)</p> <p>2. Down Hereford Branch to :—</p> <p>(a) No. 2 Line (Down Main)</p> <p>(b) No. 1 Line (Up Main)</p> <p>(Junction Indicator displayed)</p> <p>When displaying a single yellow or green without the Junction Indicator, this signal acts as No. 2 Line Down Main Inner Distant for Newport East</p>	41 m. 1,234yds.

NEWPORT EAST SIGNAL BOX (DOWN MAIN LINE)

PROFILE No.	SIGNAL No.	APPLICATION	MILEAGE
1	N 224	<p>1. Route Indicator working with main aspect 2 (a), 2 (b) or 2 (c) and with calling-on aspect 3 (a) or 3 (b)</p> <p>2. No. 2 Line (Down Main) to :—</p> <p>(a) No. 6 Line (Down Platform) (Route Indication "6")</p> <p>(b) No. 4 Line (Down Relief) (Route Indication "4")</p> <p>(c) No. 2 Line (Down Main) (Route Indication "2")</p> <p>The second yellow will not be used at this stage. When displaying a double yellow or a green, this signal acts as Down Platform Line Inner Distant, Down Relief, or Down Main Intermediate Distant for Newport West.</p> <p>3. Calling-on No. 2 Line (Down Main) to :—</p> <p>(a) No. 6 Line (Down Platform) (Route Indication "6")</p> <p>(b) No. 4 Line (Down Relief) (Route Indication "4")</p> <p>The A.W.S. Ramp will be situated 65 yards to the rear of this signal.</p> <p>This signal is on a gantry, with the main aspect above the left hand rail of No. 2 Line (Down Main)</p>	158m. 480yds.

(continued)

NEWPORT EAST SIGNAL BOX (DOWN MAIN LINE) — continued

PROFILE No.	SIGNAL No.	APPLICATION	MILEAGE
1	N 124 (Down Up Main)	<p>4. Route Indicator working with main aspect 5, calling-on or shunt aspect 6</p> <p>5. No. 1 Line (Up Main) to :—</p> <p>(a) No. 6 Line (Down Platform) (Route Indication "6")</p> <p>(b) No. 4 Line (Down Relief) (Route Indication "4")</p> <p>(c) No. 5 Line (Up and Down Platform) (Route Indication "5")</p> <p>(d) No. 2 Line (Down Main) (Route Indication "2")</p> <p>(e) No. 1 Line (Up Main) (Route Indication "1")</p> <p>6. (a) to (e) Calling-on Route and Route Indications as for main aspect 5</p> <p>(f) Shunt No. 1 Line (Up Main) to No. 3 Line (Up Relief) via No. 3 Line (Up Relief) or No. 1 Line (Up Main)</p> <p>This signal is on a gantry with main aspect above left hand rail of No. 1 Line (Up Main)</p> <p>The A.W.S. Ramp will be situated 65 yards to the rear of this signal</p>	158m. 480yds.

(continued)

NEWPORT EAST SIGNAL BOX (DOWN MAIN LINE) — continued

PROFILE No.	SIGNAL No.	APPLICATION	MILEAGE
28	Down Main Starting (formerly Down Relief Starting)	<p>1. Down No. 2 Line (Down Main) to :—</p> <p>(a) No. 5 Line (Up and Down Platform) (Route Indication "5")</p> <p>(b) No. 2 Line (Down Main) (Route Indication "2")</p> <p>2. Newport West Down No. 2 line (Down Main) or No. 5 Line (Up and Down Platform) Inner Distant</p> <p>3. Calling-on Down No. 2 Line (Down Main)</p> <p>(a) No. 5 Line (Up and Down Platform) (Route Indication "5")</p> <p>(b) No. 2 Line (Down Main) (Route Indication "2")</p> <p>4. Route Indicator working with Main aspect 1 (a) or 1 (b) and calling-on aspect 3 (a) or 3 (b)</p> <p>5. Down No. 2 Line (Down Main) to No. 1 Line (Up Main)</p> <p>6. Calling-on Down No. 2 Line (Down Main) to No. 1 Line (Up Main)</p>	158m. 715yds.

MAGOR (DOWN RELIEF LINE)

PROFILE No.	SIGNAL No.	APPLICATION	MILEAGE
4	DR 151	Down Relief	151m. 1,023yds.
3	MG 402	Down Relief	152m. 506yds.
5	MG 404	<p>1. Down Relief</p> <p>2. Shunt. Down Relief to Steelworks East Ingoing Road (Route Indication "IR")</p> <p>3. Route Indicator working with shunt aspect 2</p>	152m. 1,752yds.

EAST USK CONTROL PANEL (DOWN RELIEF LINE)

PROFILE No.	SIGNAL No.	APPLICATION	MILEAGE
4	DR 153	Down Relief	153m. 1,274yds.
4	DR 154	Down Relief	154m. 823yds.
14	N 408	Down Relief	155m. 326yds.
14	N 410	Down Relief	155m. 1,634yds.
31	U 2	Steelworks West Outgoing Road to Down Relief No A.W.S. Ramp will be provided for this signal	155m. 1,715yds.
15	DR 156	Down Relief	156m. 572yds.
14	N 414	Down Relief	156m. 1,253yds.
20	N 416	1. Route Indicator working with shunt aspect 3 (a) or 3 (b) or 3 (c) 2. Down Relief 3. Shunt. Down Relief to :— (a) Down Siding (Route Indication "S") (b) Reception Siding No. 2 (Route Indication "N2") (c) Reception Siding No. 1 (Route Indication "N1") (d) Down Relief The signal is on a gantry with the main aspect above the left hand rail of the Down Relief	156m. 1,749yds.

MAINDEE MAIN CONTROL PANEL (DOWN RELIEF LINE)

PROFILE No.	SIGNAL No.	APPLICATION	MILEAGE
14	N 418	Down Relief	157m. 790yds.
21	N 420	1. Junction Indicator to Down Main working with Main Aspect 2 (b) 2. Down Relief to :— (a) Down Relief (b) Down Main (Junction Indicator displayed) When displaying a double yellow or green without the Junction Indicator, the signal acts as Down Relief Distant for Newport East	157m. 1,275yds.
9	M 4	1. Route Indicator working with main aspect 2 (a) or 2 (b) 2. Reception Siding No. 2 to :— (a) No. 4 Line (Down Relief) (Route Indication "4") (b) No. 2 Line (Down Main) (Route Indication "2") No A.W.S. Ramp will be provided for this signal	157m. 1,275yds.
14	N 422	Down Relief This signal also acts as the Down Relief Inner Distant signal for Newport East and also the Down Relief and Down Platform Line Distant signals for Newport West The indications are as follows :— Single Yellow : Caution for Newport East Double Yellow : Stop signals at Newport East off Caution for Newport West Green : Stop signals at Newport East and Newport West off	158m. 60yds.

NEWPORT WEST SIGNAL BOX (DOWN LINE)

PROFILE No.	SIGNAL No.	APPLICATION	MILEAGE
11	N 528 (No. 5 Platform Line)	<p>1. Route Indicator working with main aspect 2 (a) or 2 (b)</p> <p>2. No. 5 Line (Up and Down Platform) to :— (a) No. 4 Line (Down Relief) (Route Indication "4") (b) No. 2 Line (Down Main) (Route Indication "2")</p> <p>3. Shunt. No. 5 Line (Up and Down Platform) to Up Platform Siding (Route Indication "S")</p> <p>4. Route Indicator working with shunt aspect 3. This signal is on the end of No. 5 Platform at the right hand side of the Up and Down Platform Line and applies to movements in Down Direction</p>	158m. 1,285yds.
22	N 428 (Down Relief)	<p>1. Route Indicator working with main aspect 2 (a) or 2 (b)</p> <p>2. No. 4 Line (Down Relief) to :— (a) No. 4 Line (Down Relief) (Route Indication "4") (b) No. 2 Line (Down Main) (Route Indication "2") The double yellow aspect of this signal will not be in use at this stage</p> <p>3. Shunt aspect not in use at this stage This signal is on a bracket gantry with the Main aspect above the right hand rail of Down Relief</p>	158m. 1,230yds.

(continued)

NEWPORT WEST SIGNAL BOX (DOWN LINE) — continued

PROFILE No.	SIGNAL No.	APPLICATION	MILEAGE
19	N 628 (No. 6 Platform Line)	<p>Newport West Down Platform (No. 6) Line Home</p> <p>1. Route Indicator not in use at this stage</p> <p>2. No. 6 Line (Down Platform) to No. 4 Line (Down Relief) The Double Yellow aspect of this signal will not be in use at this stage.</p> <p>3. Shunt aspect not in use at this stage</p>	158m. 1,230yds.
32 (Incorrectly shown as 4 aspect signal on sketch)	W 12 (Bay)	<p>No. 7 (Bay) Platform Starting</p> <p>1. Route Indicator not in use at this stage</p> <p>2. No. 7 (Bay) Platform Line to No. 4 Line (Down Relief)</p> <p>3. Shunt. No. 7 (Bay) Platform Line to No. 1 Goods Siding (Route Indication "S")</p> <p>4. Route Indicator working with shunt aspect 3. No A.W.S. Ramp will be provided for this signal</p>	158m. 1,230yds.

NEWPORT EAST SIGNAL BOX (UP MAIN LINE)

PROFILE No.	SIGNAL No.	APPLICATION	MILEAGE
29	N. 127	<p>1. Shunt No. 1 Line (Up Main) to E.7. (No. 1 Line)</p> <p>2. Route Indicator working with main aspect 3 (a) or 3 (b)</p> <p>3. No. 1 Line (Up Main) to : (a) No. 1 Line (Up Main) (Route Indication " 1 ") (b) No. 2 Line (Down Main) (Route Indication " 2 ") This signal will be on a gantry with the main aspect on the left hand side of No. 1 Line (Up Main) The A.W.S. Ramp will be situated 75 yards to the rear of this signal. (This A.W.S. ramp will also be operated by Down trains travelling down the Up Main Line and in this direction will always give a caution indication.)</p>	158m. 906yds.
29	N. 227 (Up Down Main)	<p>4. Shunt No. 2 Line (Down Main) to E.7. (No. 1 Line)</p> <p>5. No. 2 Line (Down Main) to :— (a) No. 1 Line (Up Main) (Route Indication " 1 ") (b) No. 2 Line (Down Main) (Route Indication " 2 ")</p> <p>6. Route Indicator not in use at this stage</p> <p>7. Route Indicator working with main aspect 5 (a) or 5 (b) This signal will be on a gantry with the main aspect on the left hand side of No. 2 Line (Down Main) The A.W.S. Ramp will be situated 75 yards to the rear of this signal. (This A.W.S. ramp will also be operated by Down trains travelling down the Down Main Line and in this direction will only give a proceed indication when all Newport West Stop signals are off.)</p>	158m. 906yds.

MAINDEE MAIN CONTROL PANEL (UP MAIN LINE)

PROFILE No.	SIGNAL No.	APPLICATION	MILEAGE
23	N 129	<p>1. Junction Indicator to Up Hereford Branch working with main aspect 3 (b)</p> <p>2. Junction Indicator to Up Hereford Goods Line working with main aspect 3 (a)</p> <p>3. Up Main to :— (a) Up Hereford Goods Line (Junction Indicator " 2 " displayed) (b) Up Hereford Branch (Junction Indicator " 1 " displayed) (c) Up Main</p> <p>4. Calling-on aspect not in use at this stage When displaying a single Yellow or Green with Junction Indicator 1 displayed this signal acts as Up Hereford Branch Distant for Maindee Junction North This signal is on a gantry with the signal over the left hand rail of the Up Main The A.W.S. Ramp will be situated 65 yards to the rear of this signal</p>	158m. 343yds.
23	N 229 (Up Down Main)	<p>5. No. 2 Line (Down Main) to No. 1 Line (Up Main) This signal is on a gantry with the signal over the left hand rail of No. 2 Line (Down Main) The A.W.S. Ramp will be situated 65 yards to the rear of this signal</p>	158m. 343yds.
10	N 131	<p>1. Junction Indicator to Up Relief working with main aspect 2 (b)</p> <p>2. Up Main to :— (a) Up Main (b) Up Relief (Junction Indicator displayed)</p> <p>3. Shunt Up Main to Reception Siding No. 1 (Route Indication " N1 ") This shunt aspect requires a shunter's release</p> <p>4. Route Indicator working with shunt aspect 3 The A.W.S. Ramp will be situated 160 yards to the rear of this signal</p>	157m. 1,721yds.

(continued)

MAINDEE MAIN CONTROL PANEL (UP MAIN LINE) — continued

PROFILE No.	SIGNAL No.	APPLICATION	MILEAGE
10	N 031 (Up Maindee Loop)	1. Junction Indicator to Up Relief working with main aspect 2 (b) 2. Up Maindee Loop to :— (a) Up Main (b) Up Relief (Junction Indicator displayed) 3. Shunt. Up Maindee Loop to Reception Siding No. 1 (Route Indication "N1") This shunt aspect requires a shunter's release 4. Route Indicator working with shunt aspect 3	41m. 1,310yds.
3	N 133	Up Main	157m. 800yds.

EAST USK CONTROL PANEL (UP MAIN LINE)

PROFILE No.	SIGNAL No.	APPLICATION	MILEAGE
8	N 135	1. Up Main 2. Shunt. Up Main	157m. 40yds.
3	N 139	Up Main	156m. 91yds.

MAGOR (UP MAIN LINE)

PROFILE No.	SIGNAL No.	APPLICATION	MILEAGE
4	UM 155	Up Main	155m. 764yds.
4	UM 154A	Up Main	154m. 1,329yds.
4	UM 154B	Up Main	154m. 136yds.
4	UM 153	Up Main	153m. 700yds.
4	UM 152	Up Main	152m. 1,232yds.
3	MG 103	Up Main	152m. 40yds.
3	MG 3	Up Main	151m. 535yds.

NEWPORT EAST (UP RELIEF LINE)

PROFILE No.	SIGNAL No.	APPLICATION	MILEAGE
30	N. 527 (No. 5 Platform Line)	1. Route Indicator not in use at this stage 2. Route Indicator working with main aspect 3 (a) or 3 (b) or 3 (c) 3. No. 5 Line (Up and Down Platform) to :— (a) No. 1 Line (Up Main) (Route Indication "1") (b) No. 2 Line (Down Main) (Route Indication "2") (c) No. 3 Line (Up Relief) (Route Indication "3") 4. Shunt No. 5 Line (Up and Down Platform) to E.7. (No. 1 Line). When displaying a double Yellow or Green with route indication "3" displayed, this signal acts as Up Relief or Up Relief to Up Main Distant for Maindee Main The signal will be on a gantry with main aspect on the left hand side of No. 5 Line (Up and Down Platform)	158m. 884yds.
30	N. 327	5. Route Indicator not in use at this stage 6. Route Indicator working with main aspect 7 (a) or 7 (b) 7. No. 3 Line (Up Relief) to :— (a) No. 1 Line (Up Main) (Route Indication "1") (b) No. 3 Line (Up Relief) (Route Indication "3") When displaying a double Yellow or Green with route indication "3" displayed, this signal acts as Up Relief or Up Relief to Up Main Distant for Maindee Main 8. Shunt No. 3 Line (Up Relief) to E.7. (No. 1 Line). The signal will be on a gantry with the main aspect on the left hand side of No. 3 Line (Up Relief)	158m. 884yds.

MAINDEE MAIN CONTROL PANEL (UP RELIEF LINE)

PROFILE NO.	SIGNAL NO.	APPLICATION	MILEAGE
16	N 329	1. Junction Indicator to Up Main working with main aspect 2 (a) 2. Up Relief to :— (a) Up Main (Junction Indicator displayed) (b) Up Relief	158m. 327yds.
17	N 331	1. Up Relief 2. Shunt. Up Relief to Reception Siding No. 1 (Route Indication "N1") This shunt aspect requires a shunter's release 3. Route Indicator working with shunt aspect 2	157m. 1,575yds.

EAST USK CONTROL PANEL (UP RELIEF LINE)

PROFILE NO.	SIGNAL NO.	APPLICATION	MILEAGE
14 7	N 333 N 335	Up Relief 1. Junction Indicator to Up Main working with Main aspect 3 (a) 2. Junction Indicator to the East Usk Up Branch working with Main aspect 3 (c) or Call-on aspect 4 (c) 3. Up Relief to :— (a) Up Main (Junction Indicator "1" displayed) (b) Up Relief (c) East Usk Up Branch (Junction Indicator "2" displayed) 4. (a) Shunt. Up Relief (b) Shunt. Up Relief to East Usk Up Branch (c) Calling-on Up Relief to East Usk Up Branch (Junction Indicator "2" displayed)	157m. 800yds. 157m.
3 5	N 337 N 339	Up Relief 1. Up Relief 2. Shunt. Up Relief to Steelworks West Ingoing Road (Route Indication "SW") 3. Route Indicator working with shunt aspect 2	156m. 1,280yds. 156m. 91yds.

MAGOR (UP RELIEF LINE)

PROFILE NO.	SIGNAL NO.	APPLICATION	MILEAGE
4	UR 155	Up Relief	155m. 764yds.
4	UR 154A	Up Relief	154m. 1,329yds.
4	UR 154B	Up Relief	154m. 136yds.
3	MG 301	Up Relief	153m. 700yds.
31	MG 501	Steelworks East outgoing road to Up Relief No A.W.S. Ramp will be provided for this signal	153m. 210yds.
4	UR 152	Up Relief	152m. 1,232yds.
3	MG 303	Up Relief	152m. 40yds.
10	MG 2	1. Junction Indicator to Up Main working with main aspect 2 (b) 2. Up Relief to :— (a) Up Goods (b) Up Main (Junction Indicator displayed) 3. (a) Shunt. Up Relief to Up Siding (Route Indication "US") (b) Calling-on Up Relief to Up Goods 4. Route indicator working with shunt aspect 3 (a)	151m. 535yds.

EAST USK MECHANICAL

PROFILE No.	SIGNAL No.	APPLICATION	MILEAGE
6	MU 5	1. East Usk Down Branch to Down Relief 2. Shunt. East Usk Down Branch to :— (a) Down Sidings (Route Indication " S ") (b) Reception Siding No. 2 (Route Indication " N.2 ") (c) Reception Siding No. 1 (Route Indication " N.1 ") 3. Route Indicator working with shunt aspect 2 (a) or 2 (b) or 2 (c) No A.W.S. Ramp will be provided for this signal	156m. 1,710yds.
13	East Usk Up Branch Starting	Up Branch	250yds. from East Usk Mechanical Box

New Ground Signals

New position light ground signals will be brought into use as shown on the attached sketch. These new position light ground signals will conform with profile number 24.

The routes of these new position light ground signals, controlled from the new signal boxes are as follows :—

(a) East Usk

U.8 (a) U.10 signal (b) Down Main (No. 2 Line)	U.10 (a) Down Relief (No. 4 Line) (b) Up Relief Limit of Shunt (No. 3 Line)
MU.17 (a) Down Sidings (b) Reception Siding No. 2 (c) Reception Siding No. 1 (d) Down Relief (No. 4 Line)	* MU.35 (a) Up Main (No. 1 Line) (b) Up Relief (No. 3 Line) (c) Up East Usk Branch (d) Down East Usk Branch
U.3 MU.35 signal	MU.37 MU.35 signal
MU.38 MU.35 signal	MU.39 MU.35 signal

* Incorrectly shown as U.35 on sketch

(b) Maindee Main

M.1 (a) Reception Siding No. 1 (b) Reception Siding No. 2	M.2 (a) Down Relief (No. 4 Line) (b) Down Main (No. 2 Line)
--	--

(c) Newport East

E.7 Up Main (No. 1 Line)

The following double disc shunt signal will be brought into use :—

Bottom Disc (reference " X " on sketch)	Up No. 2 Line
Top Disc	Up No. 2 Line to No. 1 Line (this disc was previously Down Relief to Up Relief).

Eask Usk — Limit of Shunt

A Limit of Shunt (Profile 26) for movements Down the Up Relief will be provided situated on Down Side of the Up Relief at 157m. 200 yds.

Existing Signals Renamed and/or Re-routed, or with Additional Routes

Existing	To Become
Maindee Junction East	Maindee Main
Up Maindee Loop Distant	Up Maindee Loop Distant
Up Maindee Loop Inner Distant	Up Maindee Loop Inner Distant
Up Main Distant	Up Relief Inner Distant
Maindee Junction North	Maindee Main
Up Main to Up Hereford Line Distant	Up Main from Up Relief Inner Distant

Maindee Junction North

To Cardiff Starting
To London Starting
From avoiding line to London
Starting

Newport East

Down Relief Inner Distant from
Hereford Branch

Down Relief Distant from Hereford
Branch

Newport East

Down Main Inner Home

The remainder of Newport East signals and discs and also Newport West signals and discs will have their names amended in accordance with the change in name of the line and platforms.

Gaer Junction

Down Main Inner Distant
Down Main Inner Home

Up Main Home
Up Main to Up Relief Home

The remainder of Gaer Junction signals and discs, with the exception of the Up Main Distant, Intermediate Distant and Inner Distant whose names remain as existing, will have the wording of the names amended as follows:—

Main becomes Relief
Relief becomes Main

Telephones

Telephones giving exclusive communication with the controlling Signal Box will be provided as follows:—

- (1) At all multiple aspect signals with the exception of Magor Down Main Distant. In case of automatic signals communication will be with the signal box in advance, with the exception of the following:—

DM. 151	} Communicate with Magor Signal Box
DM. 152 A	
DM. 152 B	
DR. 151	

- (2) Eastern Inlet to Steelworks. Communicates with Magor Signal Box.
(3) Western Inlet to Steelworks. Communicates with East Usk (Panel) Box.
(4) Between Crossover Up Relief to Down Main and Crossover Down Main to Up Main at East Usk (near 156 $\frac{3}{4}$ m.p.). Communicates with East Usk (Panel) Box.

The Signaller is called by first removing the telephone hand set from its rest and then by momentarily pressing the button on the front of the telephone.

Care must be taken to ensure that the hand set is replaced properly on its rest after use.

Maindee Junction North

Down Hereford Branch Starting
Up Loop Starting
Down avoiding line to Up Loop
Starting

Maindee Main

Down Hereford Branch Inner
Distant (also acts as Newport
East Distant)

Down Hereford Branch Distant

Newport East

Down Relief Home

Gaer Junction

Down Relief Distant
Down Relief to Down Main
Inner Home

Up Main to Up Relief Home
Up Main Home

All the above telephones, together with the omnibus, selective, box to box, control and exchange circuits, will be incorporated into telephone concentrators at the control panels.

OCCUPATION

Occupation of locking frames at Magor, Maindee Junction North, Newport East and Newport West will be required for the purpose of locking alterations.

Chief Inspector D. A. L. Jones to make all necessary arrangements for the safe working of the Line including the appointment of any Handsignalmen in accordance with Rule 77.

ACKNOWLEDGE RECEIPT**C. H. D. READ**

District Traffic Superintendent.

NEWPORT.

1961.
(W.1/10921)

Received copy of Mr. C. H. D. Read's Notice No. W. re introduction of
Stage I of Newport Multiple Aspect Signalling Scheme.

.....DATESIGNATURE

.....DEPT.STATION

To DISTRICT TRAFFIC SUPERINTENDENT
NEWPORT (W.1/10921)

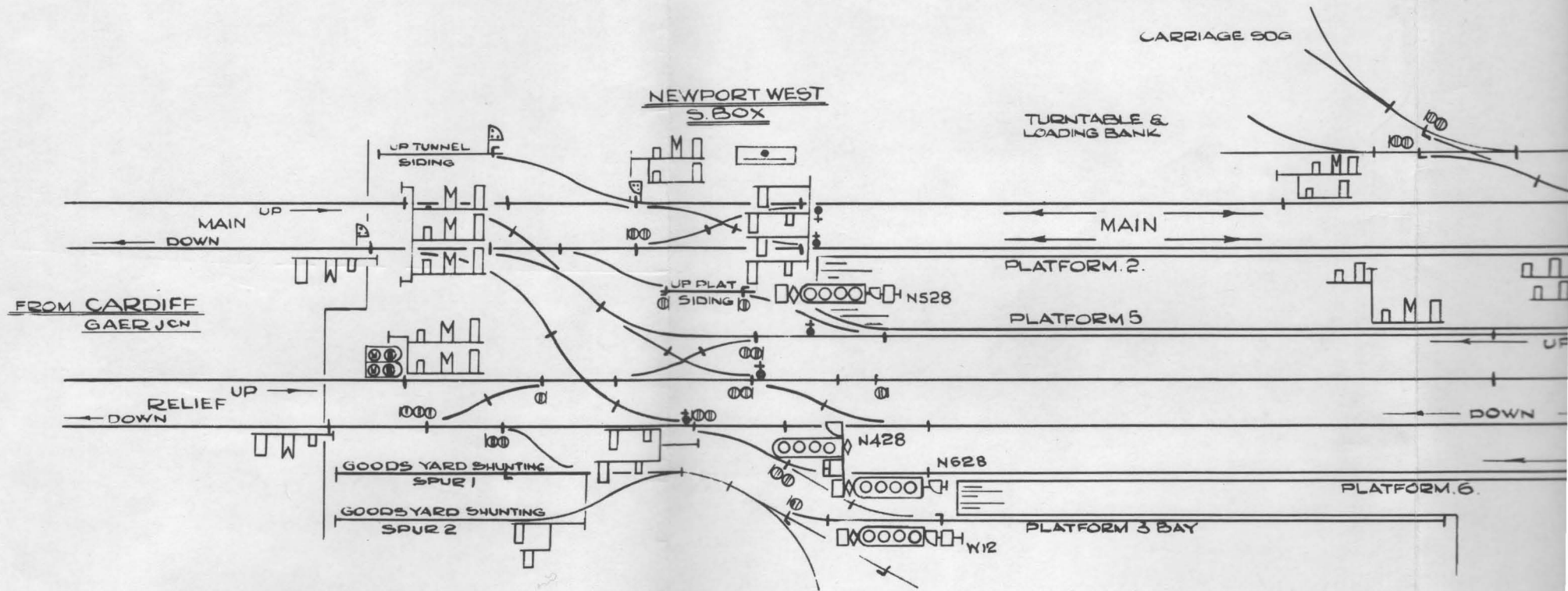

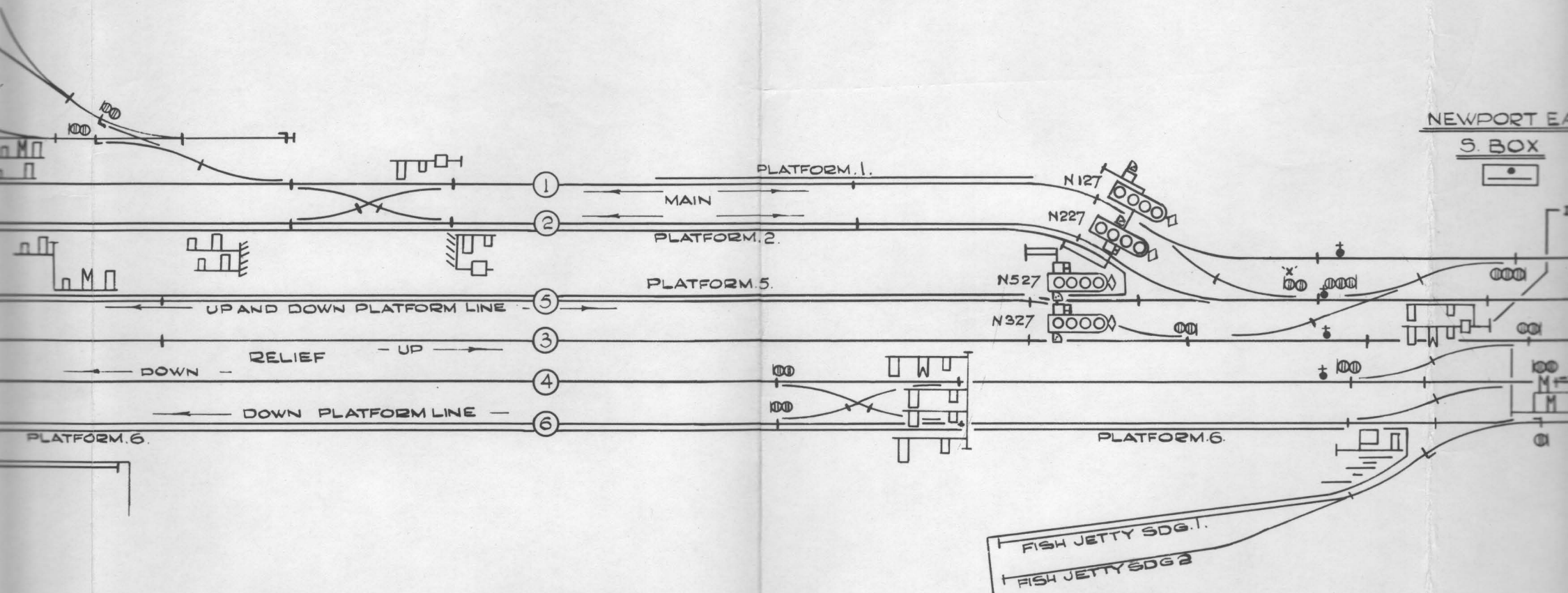

NEWPORT EAST

S. BOX



DOWN MAIN STARTING

E7

N124

N224

N129

N229

N329

N622

N131

N422

DOWN RELIEF HOMES

SPUR

158 MP

SIGNALLING CONTROL

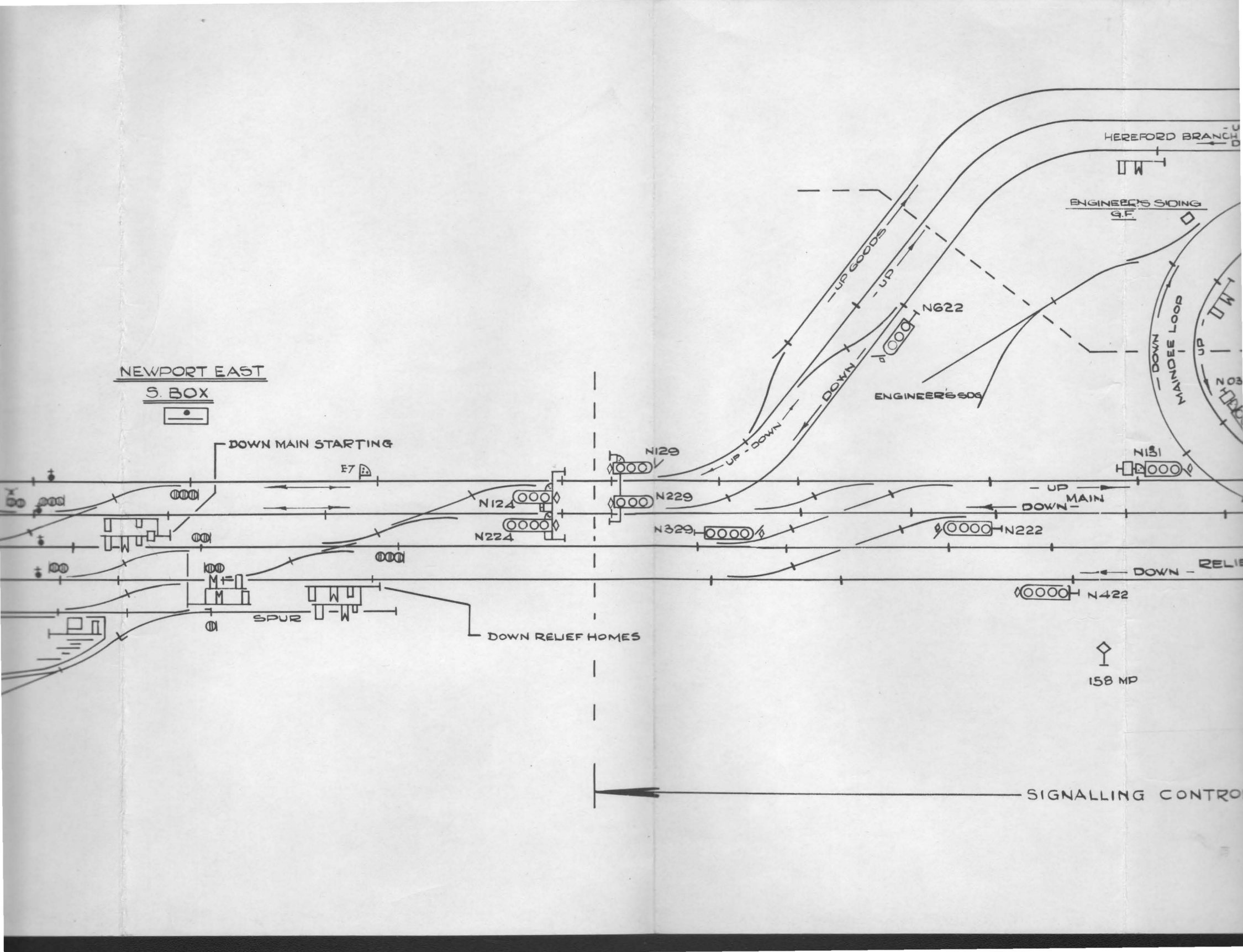

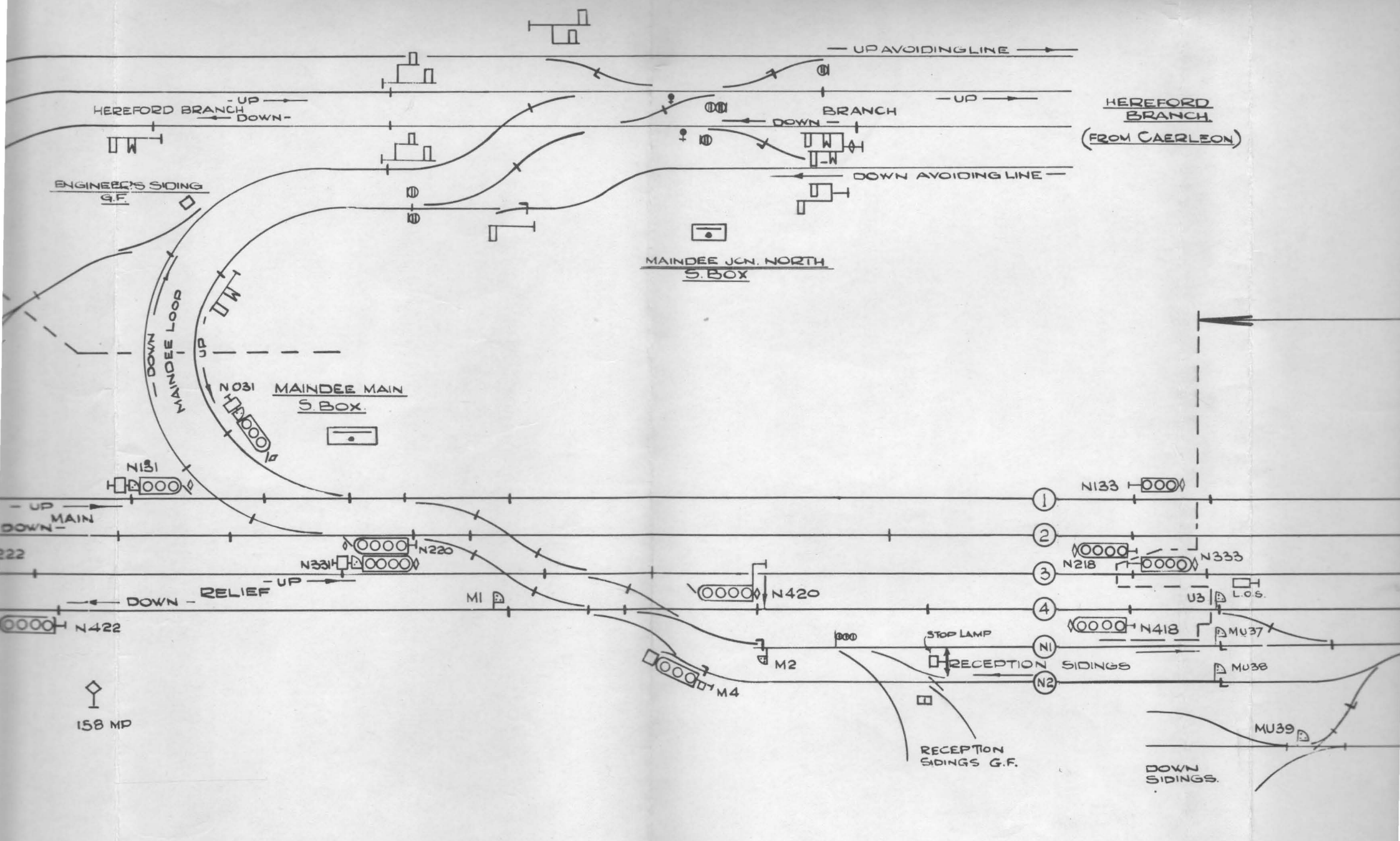

HEREFORD
BRANCH
(FROM CAERLEON)

MAINDEE JCN. NORTH
S. BOX

MAINDEE MAIN
S. BOX

- ①
- ②
- ③
- ④
- NI
- N2

SIGNALLING CONTROLLED FROM MAINDEE MAIN

PANEL
AND
MECHAN
YARD

HEREFORD
BRANCH
(FROM CAERLEON)

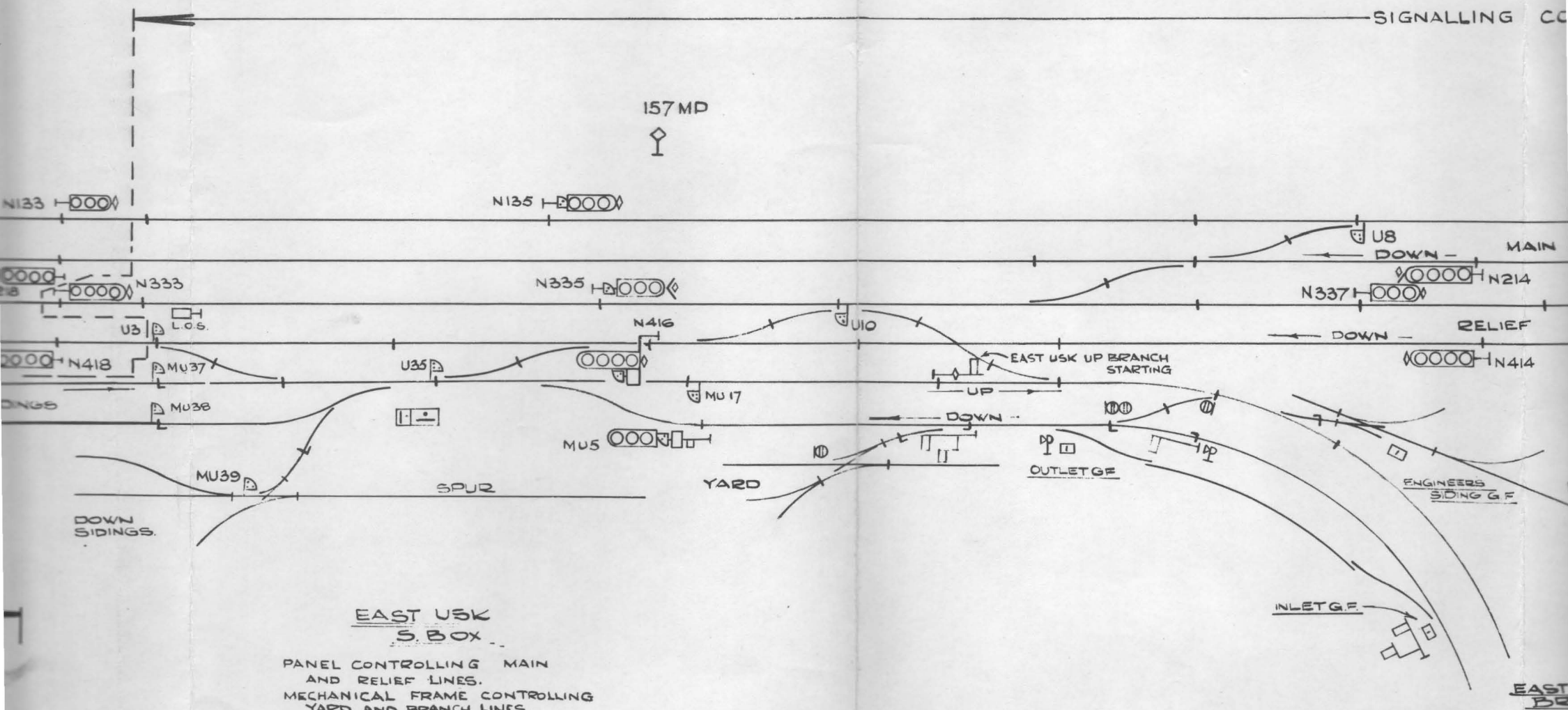

EAST USK
S BOX

PANEL CONTROLLING MAIN
AND RELIEF LINES.
MECHANICAL FRAME CONTROLLING
YARD AND BRANCH LINES.

EAST BR

NEWPORT M.A.S. STAGE I.

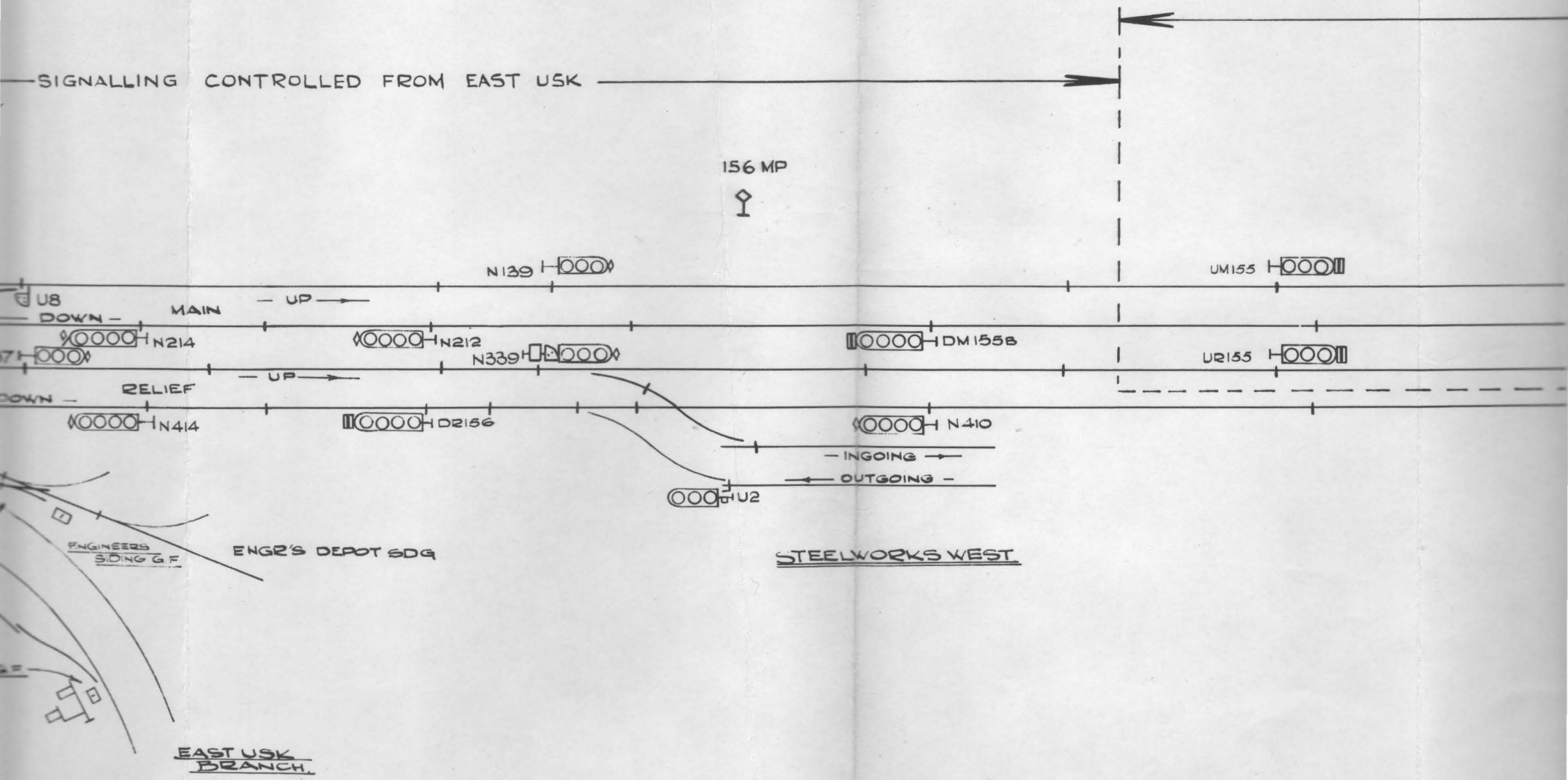

M.A.S.

AUTOMATIC SIGNALLING

155 MP

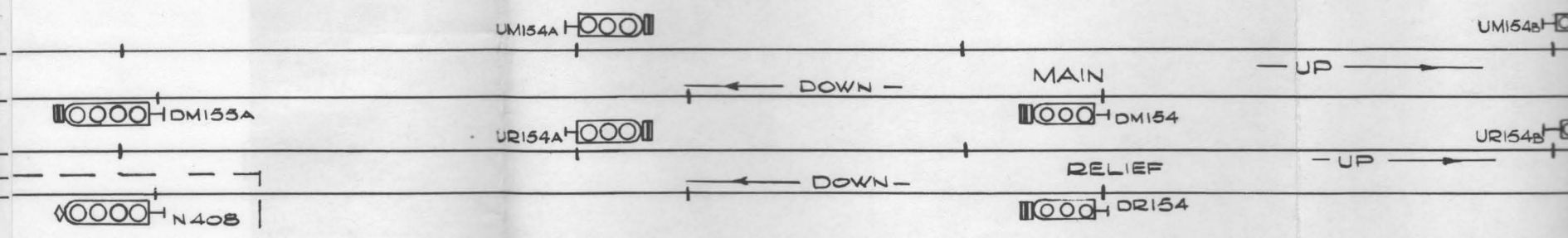

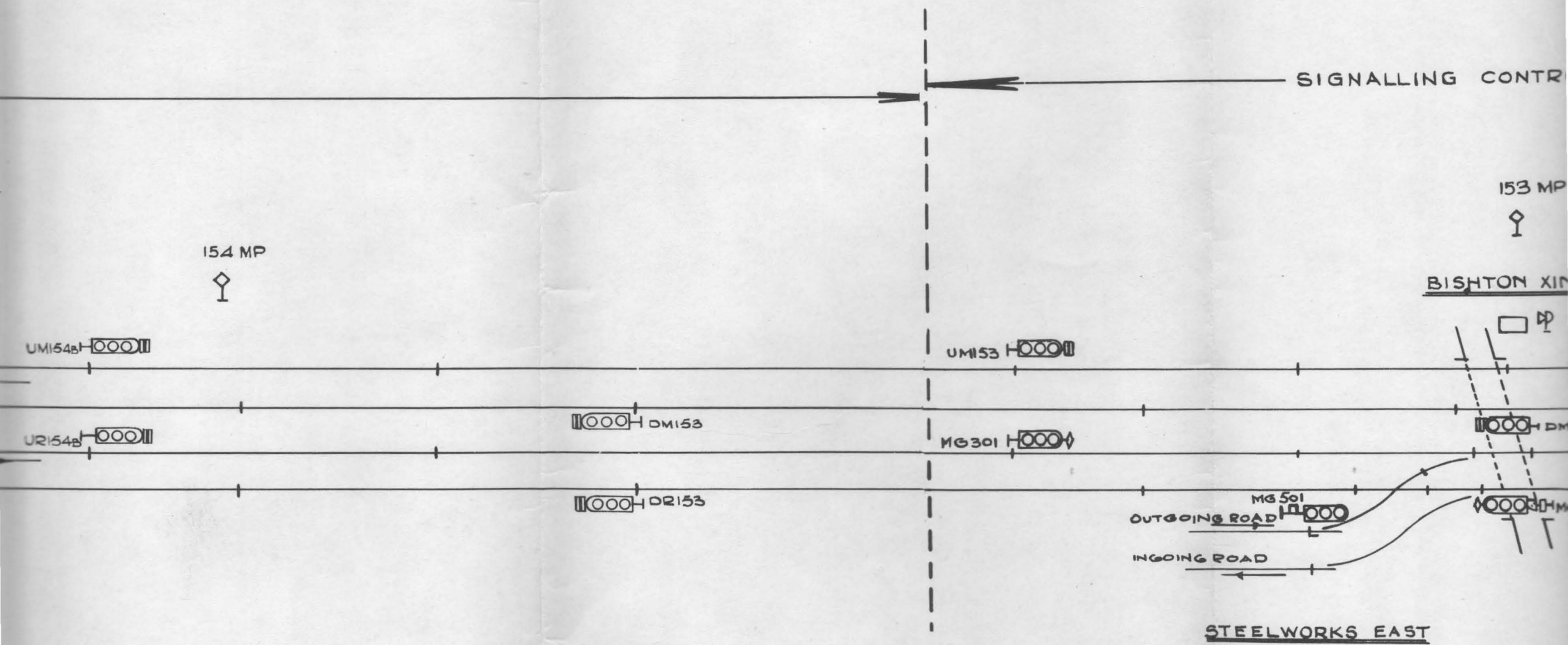

SIGNALLING CONTROLLED FROM MAGOR

153 MP



BISHTON XING GF



152 MP

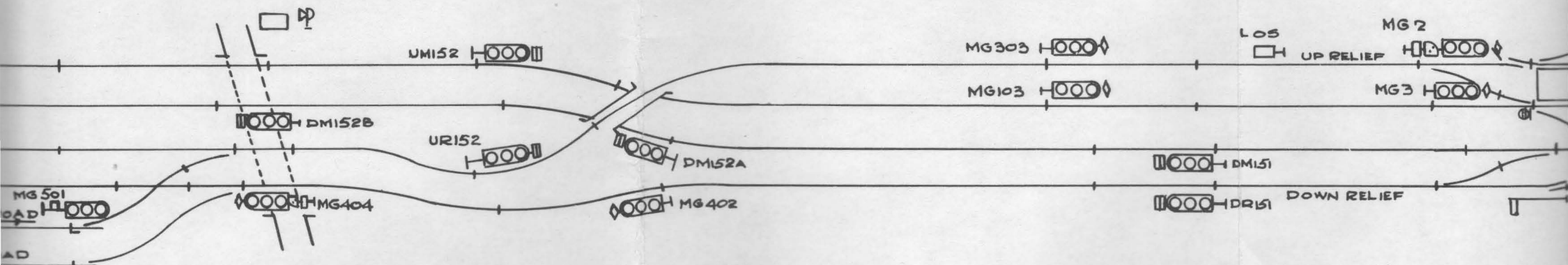

RELWORKS EAST

